

5301267

MODEL LG-3025

12 VOLT - 25 GALLON LAWN & GARDEN SPRAYER FOR ATV MOUNTING
(INCLUDES BOOMLESS NOZZLES)

ASSEMBLY / OPERATION INSTRUCTIONS / PARTS

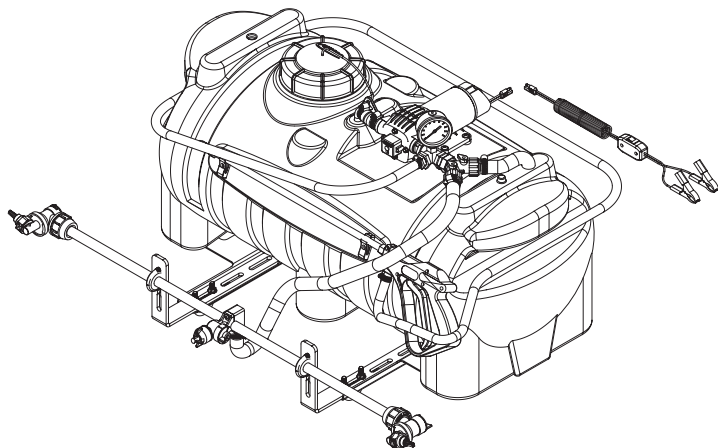

GENERAL INFORMATION

The purpose of this manual is to assist you in operating and maintaining your lawn and garden sprayer. Please read it carefully as it furnishes information which will help you achieve years of dependable trouble free operation.

WARRANTY / PARTS / SERVICE

Products are warranted for one year from date of purchase against manufacturer or workmanship defects.

Your authorized dealer is the best source of replacement parts and service. To obtain prompt, efficient service, always remember to give the following information:

1. Correct part description and part number.
2. Model Number of your sprayer.
3. Serial Number of your sprayer.

Part description and part numbers can be obtained from the illustrated parts list section of this manual.

Whenever you need parts or repair service, contact your distributor / dealer first. For warranty work always take your original sales slip, or other evidence of purchase date, to your distributor / dealer.

TECHNICAL SPECIFICATIONS

- Corrosion Resistant Polyethylene Tank.
- 12 Volt Diaphragm Pump - Demand Switch.
- Pressure Gauge-Adjustable Pressure Range.
- Handgun w/ Adjustable Nozzle
- 15 Foot Handgun Hose.
- 30 Ft. Spray Coverage
- Corrosion Resistant Nozzles

CAUTION: Always check the vehicle load rating before using this sprayer. The loaded weight of the sprayer and boom assembly is about 290 lbs. when the tank is full. Care must be taken not to tip the vehicle over backwards, especially when starting or accelerating.

ASSEMBLY

This sprayer is partially assembled at the factory. Assembly may be completed by following these steps.

1. Attach the tank to the brackets as shown in the exploded view.
2. Place the sprayer onto the carrier rack of the ATV. Use the u-bolts and hardware to secure the tank mount to the rack.
3. Connect the boom mounting brackets to the tank mounting brackets with hardware provided as shown.
4. Affix the boom to the boom mounting brackets with u-bolts (Item 7) & whiz locknuts (Item 1). Make sure the u-bolts are positioned within the grooves of the grommets on the boom tube.

Note: The purpose of these grommets is to prevent metal-to-metal contact between the u-bolts, boom tube, & boom mounting bracket.

The grommets will compress as you tighten the whiz nuts on the u-bolts. Tighten just so that the boom tube will NOT rotate within the grommets. Alternate the tightening of the locknuts to provide even pressure on the grommet.

DO NOT over-tighten the whiz locknuts, as this may cause the boom tube to flatten slightly.

5. Connect the wiring from the pump to the 12 volt power source of the vehicle. The red wire of the two wire set must be connected to the positive post on the battery or the "Hot" connection on a switch or to the ammeter. The brown wire may be grounded or connected to the negative battery post.



WWW.FIMCOINDUSTRIES.COM

1000 FIMCO LANE • P.O. BOX 1700 • NO. SIOUX CITY, SD 57049
TOLL FREE: 800-831-0027 • TOLL FREE FAX: 800-494-0440
Form No. 742 (5004577 5/06) Printed In U.S.A.

6. The pressure gauge is shipped in a parts bag. Thread the gauge into the tee fitting as shown on the exploded view drawing. Use a good quality thread sealant to prevent leaks.

The in-line switch turns the unit on and off. Running the pump dry will not harm the pump for short periods of time. Read the operating instructions and then run the sprayer using only water for testing. When everything tests all right, add the desired chemical mixture and water combination and start the spraying operation.

OPERATION

Always fill the tank with a desired amount of water first, and then add the chemical slowly mixing as you pour the chemical into the tank. You may use the handgun to spray into the solution in order to mix the chemical and water.

Initially begin spraying by opening the handgun. This will enable the air in the line to be eliminated through the tip, while building pressure.

The pumping system draws solution from the tank, through the strainer, and to the pump. The pump forces the solution under pressure to the handgun or boom nozzles.

Pressure may be decreased by opening the bypass valve to the tank. When it is closed the highest spraying pressure will be reached.

- Open the handgun by squeezing the handle lever
- Rotating the adjustable nozzle tip on the handgun will change the tip from a straight stream to a cone pattern (finer mist). Be sure the thumb nut on the adjustment nozzle is tight.
- The pump motor's demand switch shuts off the motor when the handgun, bypass valve and boom lines are fully closed. The system remains pressurized, and the pump motor will restart automatically when the handgun or boom line is opened. If however, the bypass line is open, the pump will not shut off automatically.
- The 3 nozzles are fixed on 17 1/2" spacing.
- All three nozzles spraying at the same time will allow a maximum coverage of 30 ft. Overlapping of the ends of the spray pattern will not be needed.
- The center nozzle will cover a 80" swath.
- Each of the three nozzles has a means of shutting down, so you may choose the coverage that is needed.

When it becomes necessary to clean the screen in the suction line, remove the screen from the bottom of the suction tube. Reach into the tank through the fill opening, slide the tube to one side and slip the screen from the bottom of the tube. The screen may now be tapped or flushed with clear water for cleaning.

WARNING: Some chemicals will damage the pump valves if allowed to soak untreated for a length of time. Always flush

the pump with water after use. Do not allow chemicals to sit in pump for extended times if idleness. Follow chemical manufacturers instructions on disposal of all waste water from the sprayer.

ADJUSTING PRESSURE

- When the bypass valve is closed, pressure is at the highest point.
- Opening the valve will decrease pressure.

USING THE BOOM NOZZLES

- Four things must be considered before spraying with the boom.
 1. How much chemical must be mixed in the tank.
 2. Rate of spray (gallons per acre to be sprayed).
 3. What pressure (P.S.I.) will be used.
 4. Speed traveled (M.P.H.) while spraying.
- Refer to the chemical label to determine the chemical mixture.
- See the tip chart to determine the pressure to be used. The chart will also show the speed used when spraying.
- Start the pump and open the "Y" valve to the boom nozzles.
- Check the spray pattern. Usually you can see the coverage better on solid concrete surface, such as a driveway.
- The boomless nozzles should be 33" above the objects being sprayed.

End Nozzle Information
(#5275122)

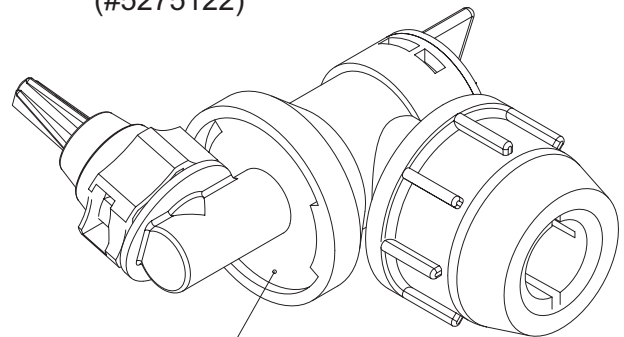

This nozzle mounting stem has a ratcheting motion.

**** Each "click" of the ratcheting motion is approx. 15° ****

For proper/optimal spray coverage, the nozzle must be at a 15° angle

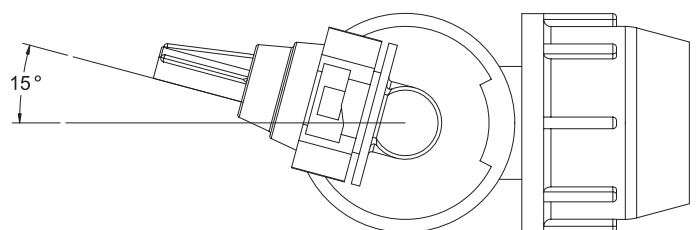

The 15° angle shown will prevent the outer nozzles from overlapping with the center nozzle.

Rate Chart for Boomless Nozzle (Set of 3)

Gallons per Acre Based on Water - 17 1/2" Spacing								
Note: The same figures are used for 1, 2, or 3 nozzles.								
Pressure P.S.I.	Capacity G.P.M. (for 3 Nozzles)	1 MPH	2 MPH	3 MPH	4 MPH	5 MPH	6 MPH	8 MPH
20	1.68	28.0	14.0	9.4	7.0	5.6	4.7	3.5
30	2.05	34.4	17.2	11.4	8.6	6.9	5.7	4.3
40	2.40	39.6	19.8	13.2	9.9	7.9	6.6	5.0

Gallons per 1000 Sq. Ft. Based on Water - 17 1/2" Spacing								
Pressure P.S.I.	Capacity G.P.M. (for 3 Nozzles)	1 MPH	2 MPH	3 MPH	4 MPH	5 MPH	6 MPH	8 MPH
20	1.68	0.64	0.32	0.21	0.16	0.13	0.11	0.08
30	2.05	0.78	0.39	0.26	0.20	0.16	0.13	0.10
40	2.40	0.90	0.45	0.30	0.23	0.18	0.15	0.12

Gallons per 100 Sq. Ft. Based on Water - 17 1/2" Spacing								
Pressure P.S.I.	Capacity G.P.M. (for 3 Nozzles)	1 MPH	2 MPH	3 MPH	4 MPH	5 MPH	6 MPH	8 MPH
20	1.68	0.064	0.032	0.021	0.016	0.013	0.011	0.008
30	2.05	0.078	0.039	0.026	0.020	0.016	0.013	0.010
40	2.40	0.090	0.045	0.030	0.023	0.018	0.015	0.012

MPH = Miles Per Hour / FPM = Feet Per Minute / PSI = Pounds Per Square Inch / GPM = Gallons Per Minute

** The rate of spray as shown in the chart will remain the same with 1, 2, or 3 Nozzles. **
The only difference will be with the width of the spray swath.

CALIBRATION

Chemical labels may show application rates in gallons per acre, gallons per 1000 square feet, or gallons per 100 square feet. You will note that the tip chart above shows all three of these rating systems.

Once you know how much you are going to spray then determine (from the tip chart) the spraying pressure (PSI), and the spraying speed (MPH).

Conditions of weather and terrain must be considered when setting the sprayer. Do not spray on windy days. Protective clothing must be worn in some cases. **Be sure to read the chemical label carefully.**

If the vehicle does not have a speedometer, determining the proper speed of the tractor can be done by marking off 100, 200 and 300 feet. The speed chart indicates the number of seconds it takes to travel the distances. Using a watch or stop watch for time, set the throttle and with a running start travel the distances. Adjust the throttle until you travel the distances in the number of seconds indicated by the speed chart. Once you have reached the throttle setting needed, mark the throttle location so you can stop and go again (returning to the same speed).

Speed Chart

Speed in M.P.H. (Miles Per Hour)	Time Required in Seconds to Travel a distance of;		
	100 ft.	200 ft.	300 ft.
1.0	68	136	205
2.0	34	68	102
3.0	23	45	68
4.0	17	34	51
5.0	14	27	41
6.0	11	23	34
7.0	9.7	19	29
8.0	8.5	17	26
9.0	7.6	15	23
10	6.8	14	20

Add water to the tank and drive to the starting place for spraying. When you are ready to spray, turn the boom valve to the "on" position. This will start solution spraying from the tips. The pressure will decrease slightly when the boom is spraying. Adjust the spraying pressure by operating the by-pass valve.

After testing, add water and chemical to the tank. Adjust the pressure and spray as you did in the testing procedure.

AFTER SPRAYING

After use fill the sprayer part way with water, start the sprayer and allow clear water to be pumped through the plumbing system and out through the spray nozzles.

Refill the tank about half full with plain water and use a chemical neutralizer such as Nutra-Sol or equivalent and repeat cleaning instructions above. Flush the entire sprayer with the neutralizing agent. Follow the chemical manufacturer's disposal instructions of all wash or rinsing water.

Remove tips from the boom. Wash tips thoroughly with water or cleaning solution (appropriate for chemical used). Blow out orifice, clean and dry. If orifice remains clogged, clean it with a fine bristle (not wire) brush, or with a toothpick. Do not damage the orifice. Water rinse and dry tips before storing.

WINTER STORAGE

Drain all water out of sprayer paying special attention to pump, handgun & valve. These items are especially prone to damage from chemicals and freezing weather.

The sprayer should be winterized before storage by pumping a solution of RV anti-freeze through the entire plumbing. Proper care and maintenance will prolong the life of the sprayer.

Exploded View/Parts List: Pump #5275017

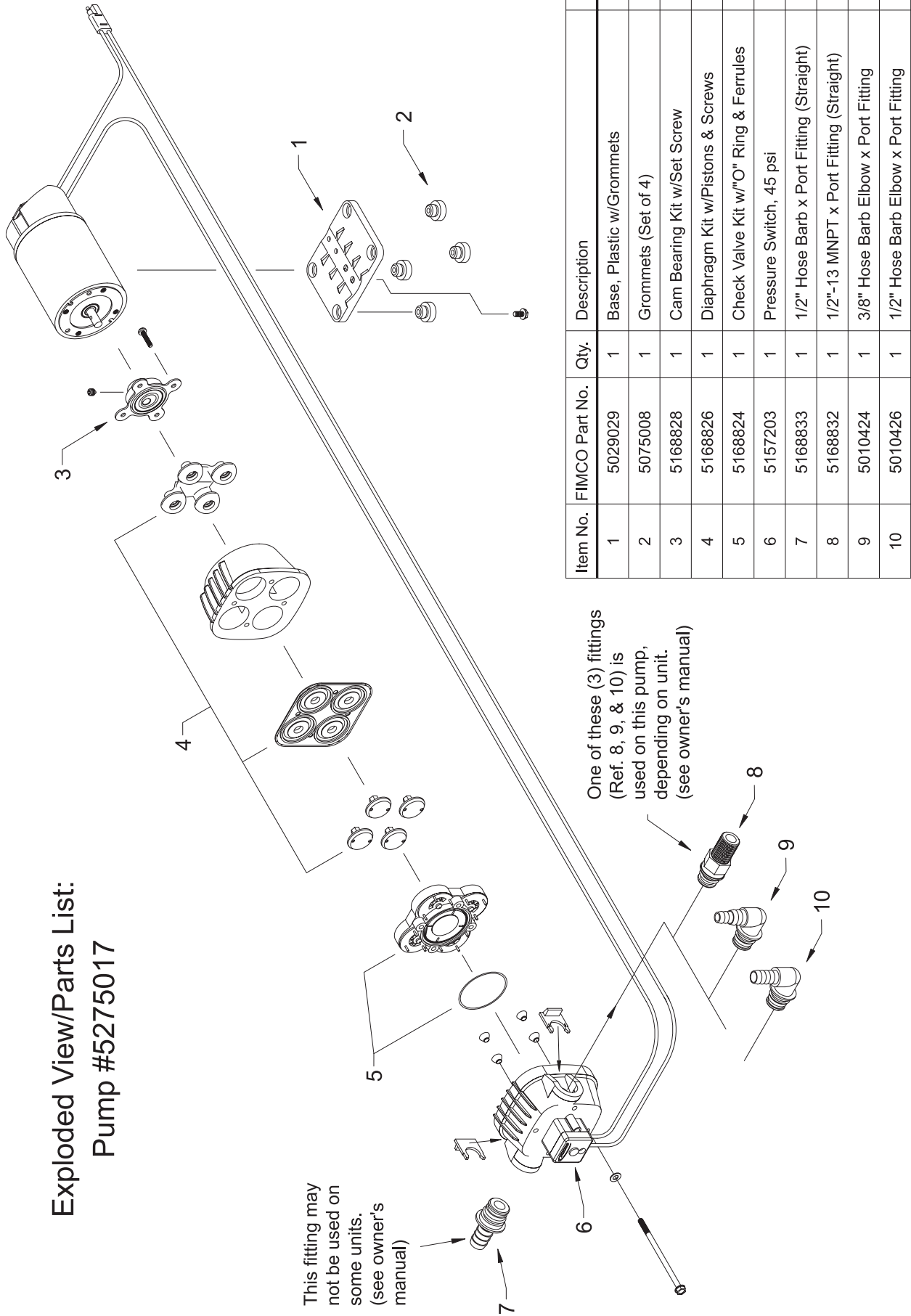

Item No.	FIMCO Part No.	Qty.	Description
1	5029029	1	Base, Plastic w/Grommets
2	5075008	1	Grommets (Set of 4)
3	5168828	1	Cam Bearing Kit w/Set Screw
4	5168826	1	Diaphragm Kit w/Pistons & Screws
5	5168824	1	Check Valve Kit w/"O" Ring & Ferrules
6	5157203	1	Pressure Switch, 45 psi
7	5168833	1	1/2" Hose Barb x Port Fitting (Straight)
8	5168832	1	1/2"-13 MNPT x Port Fitting (Straight)
9	5010424	1	3/8" Hose Barb Elbow x Port Fitting
10	5010426	1	1/2" Hose Barb Elbow x Port Fitting

Pump Assembly
#5274882

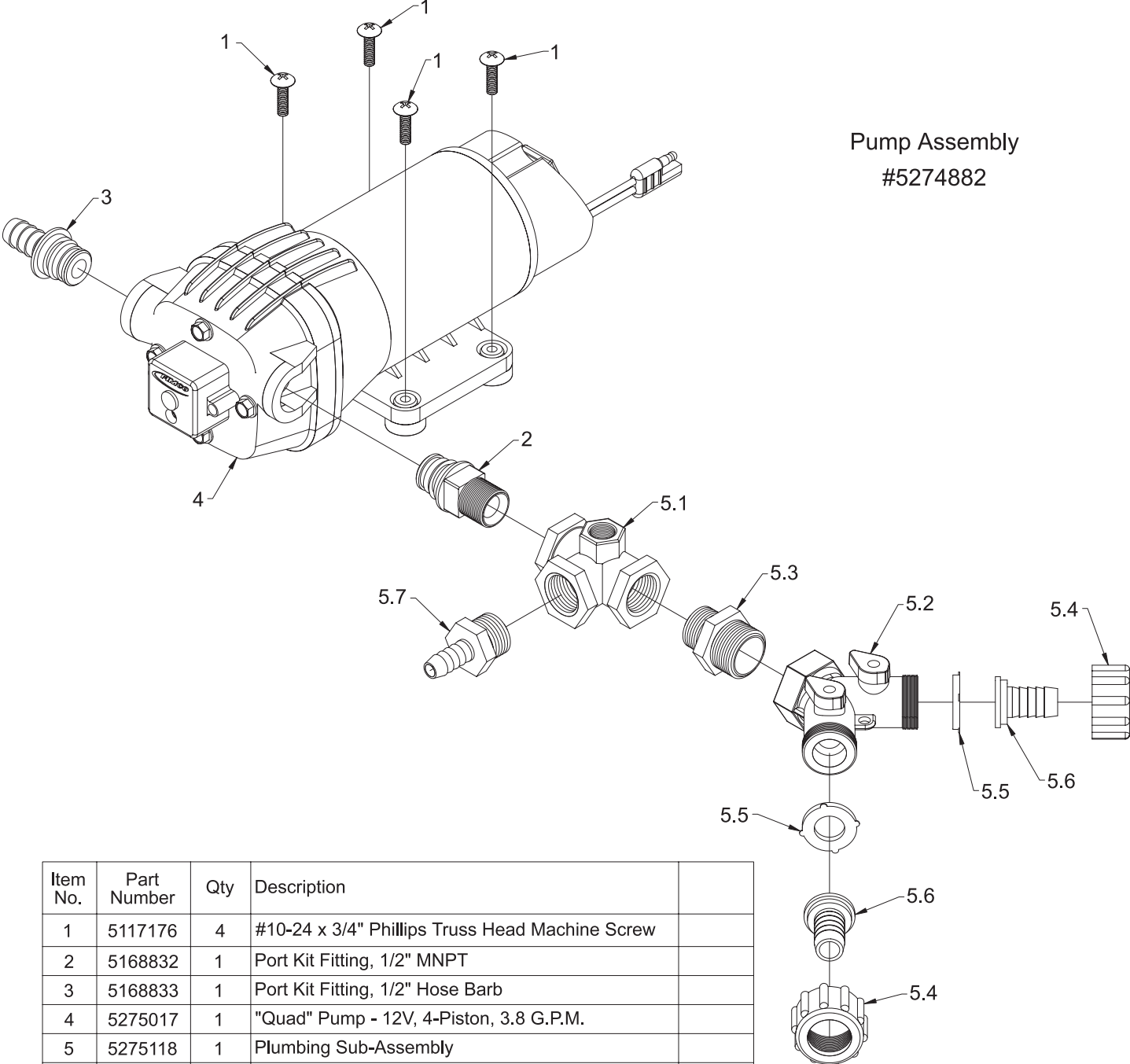

Item No.	Part Number	Qty	Description
1	5117176	4	#10-24 x 3/4" Phillips Truss Head Machine Screw
2	5168832	1	Port Kit Fitting, 1/2" MNPT
3	5168833	1	Port Kit Fitting, 1/2" Hose Barb
4	5275017	1	"Quad" Pump - 12V, 4-Piston, 3.8 G.P.M.
5	5275118	1	Plumbing Sub-Assembly
5.1	5010193	1	Nylon Tee, 1/2" FNPT w/1/4" Port (Gauge)
5.2	5143204	1	#235 Dual Hose Shut-Off "Y"-Valve, 3/4" GHT
5.3	5005021	1	Nylon Adapter, 1/2" MNPT x 3/4" MGHT
5.4	5006055	2	Nylon Knurled Swivel Nut, 3/4" FGHT
5.5	5016066	2	#102 Hose Washer (Gasket) 1" O.D. Rubber
5.6	5149011	2	Nylon Swivel, 1/2" Flat Seat Hose Barb
5.7	5067016	1	Nylon Fitting, 1/2" MNPT x 3/8" HB

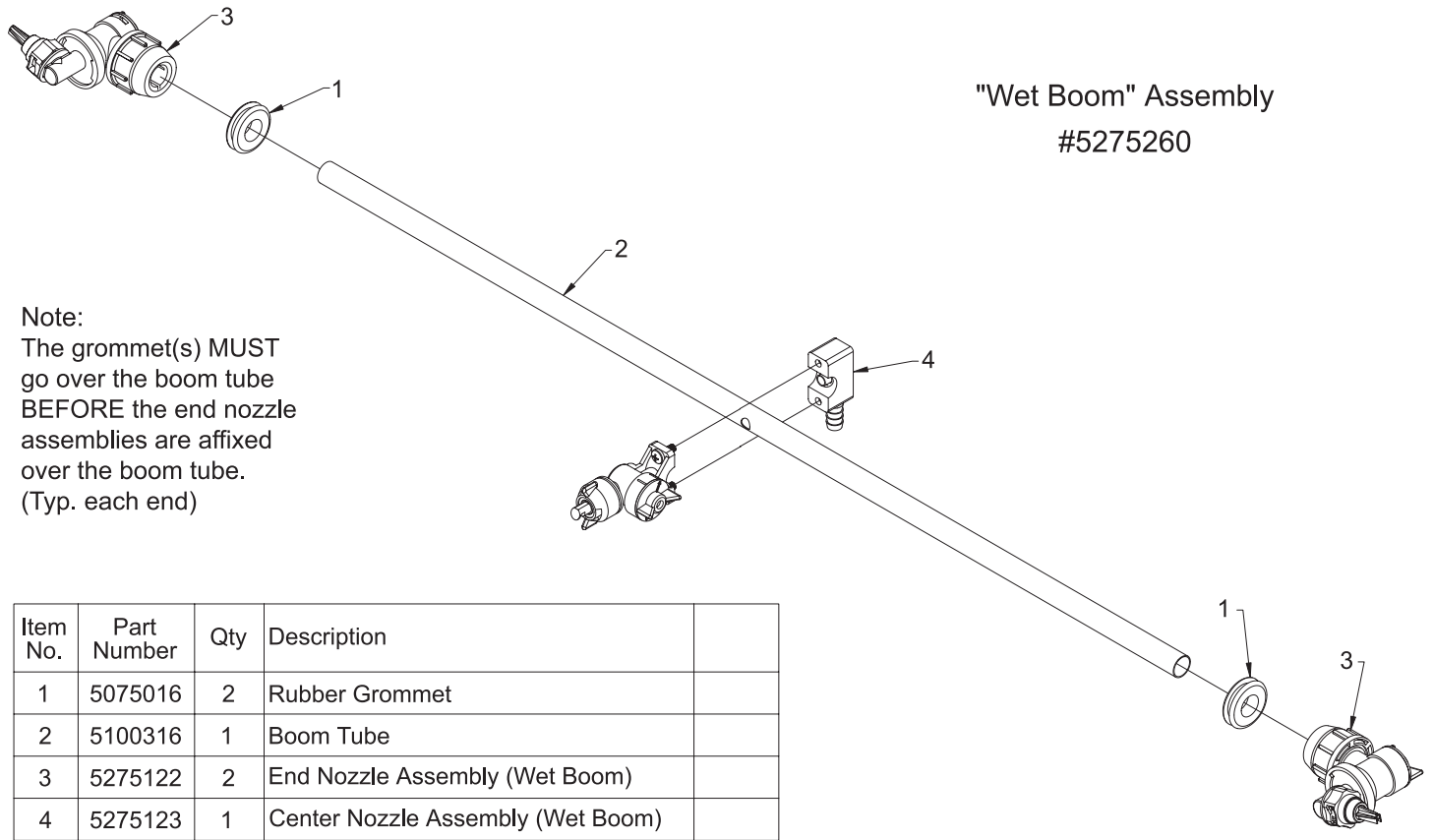

"Wet Boom" Assembly
#5275260

Note:
The grommet(s) MUST
go over the boom tube
BEFORE the end nozzle
assemblies are affixed
over the boom tube.
(Typ. each end)

Item No.	Part Number	Qty	Description
1	5075016	2	Rubber Grommet
2	5100316	1	Boom Tube
3	5275122	2	End Nozzle Assembly (Wet Boom)
4	5275123	1	Center Nozzle Assembly (Wet Boom)

Valve "Open"

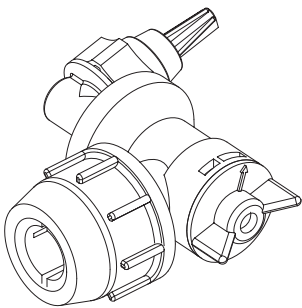

Valve "Closed"

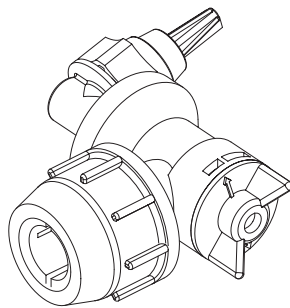

Service Position

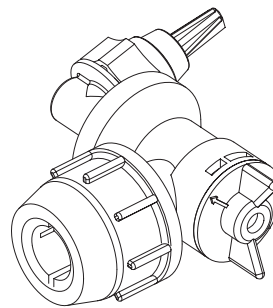

Eliminate line pressure, then pull
out to check diaphragm condition.

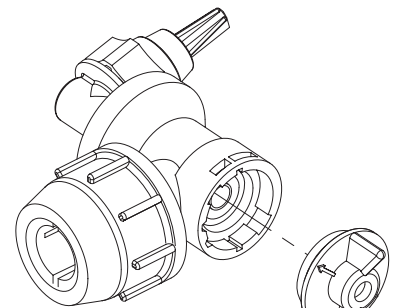

Check Valve Knob

Note: The check valve & diaphragm can fall out during transport,
if the knob is not turned to the "ON" or "OFF" position.

