

5301302
MODEL: LG-15-EC
15 GALLON LAWN & GARDEN SPOT SPRAYER

ASSEMBLY / OPERATION INSTRUCTIONS / PARTS

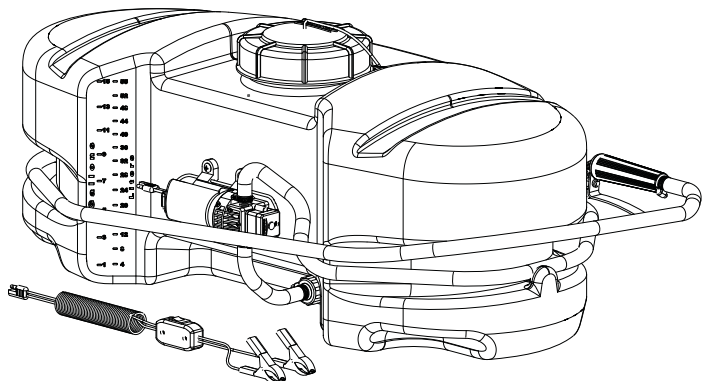

Your authorized dealer is the best source of replacement parts and service. To obtain prompt, efficient service, always remember to give the following information:

1. Correct part description and part number.
2. Model Number of your sprayer.
3. Serial Number of your sprayer.

Part description and part numbers can be obtained from the illustrated parts list section of this manual.

Whenever you need parts or repair service, contact your distributor / dealer first. For warranty work always take your original sales slip, or other evidence of purchase date, to your distributor / dealer.

**BEFORE RETURNING THIS PRODUCT
FOR ANY REASON, PLEASE CALL**

1-800-831-0027

**IF YOU SHOULD HAVE A QUESTION OR
EXPERIENCE A PROBLEM WITH YOUR
FIMCO INDUSTRIES PRODUCT:**

1-800-831-0027

**BEFORE YOU CALL, PLEASE HAVE THE
FOLLOWING INFORMATION AVAILABLE:
SALES RECEIPT & MODEL NUMBER. IN MOST
CASES, A FIMCO INDUSTRIES EMPLOYEE CAN
RESOLVE THE PROBLEM OVER THE PHONE.**

TECHNICAL SPECIFICATIONS

- Corrosion Resistant Polyethylene Tank
- 12 Volt Diaphragm Pump, Demand Switch
- 1.0 G.P.M.
- 15 Foot Handgun Hose

ASSEMBLY

The sprayer is partially assembled at the factory. The only assembly necessary is to hook up the wiring to an existing 12 volt power source. The red wire of the two wire set must be connected to the positive post on the battery or the "Hot" connection on a switch or to the ammeter. The brown wire may be grounded or connected to the negative battery post. It is important to test the sprayer with plain water before actual spraying is attempted. This will enable you to check the sprayer for leaks in the plumbing system.

GENERAL INFORMATION

The purpose of this manual is to assist you in operating and maintaining your lawn and garden sprayer. Please read it carefully as it furnishes information which will help you achieve years of dependable trouble free operation.

OPERATION

In addition to an on/off switch, the pump on the sprayer is equipped with a pressure switch that is factory set at a maximum of 35 PSI. The handgun may be shut off at anytime when the pump system is running and the pump will be electrically turned off by the pressure switch. When the handgun trigger is squeezed the pump will start again. Use care when hooking up the battery wires to the battery. Be sure the solution has



WARNING



**DO NOT USE PUMP IN AN EXPLOSIVE
ENVIRONMENT. DO NOT USE TO PUMP
FLAMMABLE FLUIDS, GASOLINE,
KEROSENE, FUEL OIL, ETC.**



WWW.FIMCOINDUSTRIES.COM

WARRANTY / PARTS / SERVICE

Products are warranted for one year from date of purchase against manufacturer or workmanship defects.





1000 FIMCO LANE • P.O. BOX 1700 • NO. SIOUX CITY, SD 57049
TOLL FREE: 800-831-0027 • TOLL FREE FAX: 800-494-0440
Form No. 1283 (5004778 2/07) Printed In U.S.A.

been added to the tank because the pump may start running as soon as the wires are attached.

The handgun has an adjustable nozzle which allows the spray to be adjusted from a cone shaped fine mist to a straight stream.

Note: The nut on the nozzle which has finger tabs must be tight in order for the spray pattern adjustment to vary when turning the nozzle end.

WARNING: Some chemicals will damage the pump valves if allowed to soak untreated for a length of time. Always flush the pump with water after use. Do not allow chemicals to sit in the pump for extended times of idleness. Flushing may be done by adding 5 gallons of water to the tank and then pump the solution through the entire system.

| |
|---|
|   CAUTION   |
| PRESSURE SWITCH OPERATION Pressure switch is pre-set at the factory. Improper adjustment of the pressure switch, may cause severe overload or premature failure. If the pump is subjected to rapid cycling during normal operation, or infrequent periods, damage may occur. |

AFTER SPRAYING

After use fill the sprayer part way with water, start the sprayer and allow clear water to be pumped through the plumbing system and out through the handgun. Use the handgun on the sprayer to thoroughly wash all internal parts of the tank and tank cover.

Refill the tank about half full with plain water and use a chemical neutralizer such as Nutra-Sol or equivalent and repeat cleaning instructions above. Flush the entire sprayer with the neutralizing agent. Follow the chemical manufacturers disposal instructions of all wash or rinsing water.

WINTER STORAGE

Drain all water out of the sprayer paying special attention to the pump, valves, and handgun. These items are especially prone to damage from chemicals and freezing weather. The sprayer should be winterized before storage by pumping a solution of RV anti-freeze through the entire plumbing. Proper care and maintenance will prolong life of the sprayer.

Exploded View/Parts List:
Pump #5275496

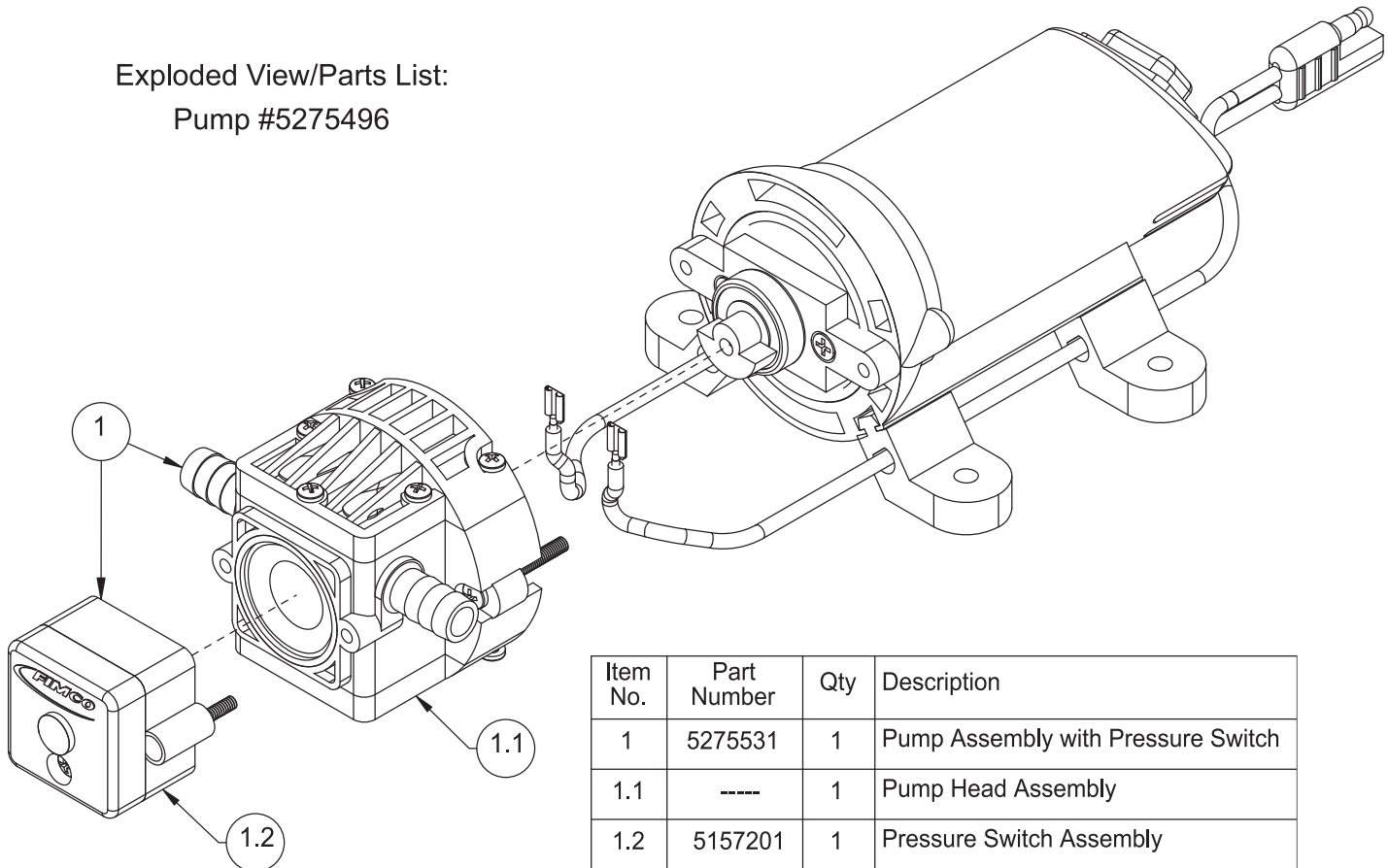

| Item No. | Part Number | Qty | Description |
|----------|-------------|-----|------------------------------------|
| 1 | 5275531 | 1 | Pump Assembly with Pressure Switch |
| 1.1 | ---- | 1 | Pump Head Assembly |
| 1.2 | 5157201 | 1 | Pressure Switch Assembly |

Exploded View/Parts List:
LG-15-EC (5301302)

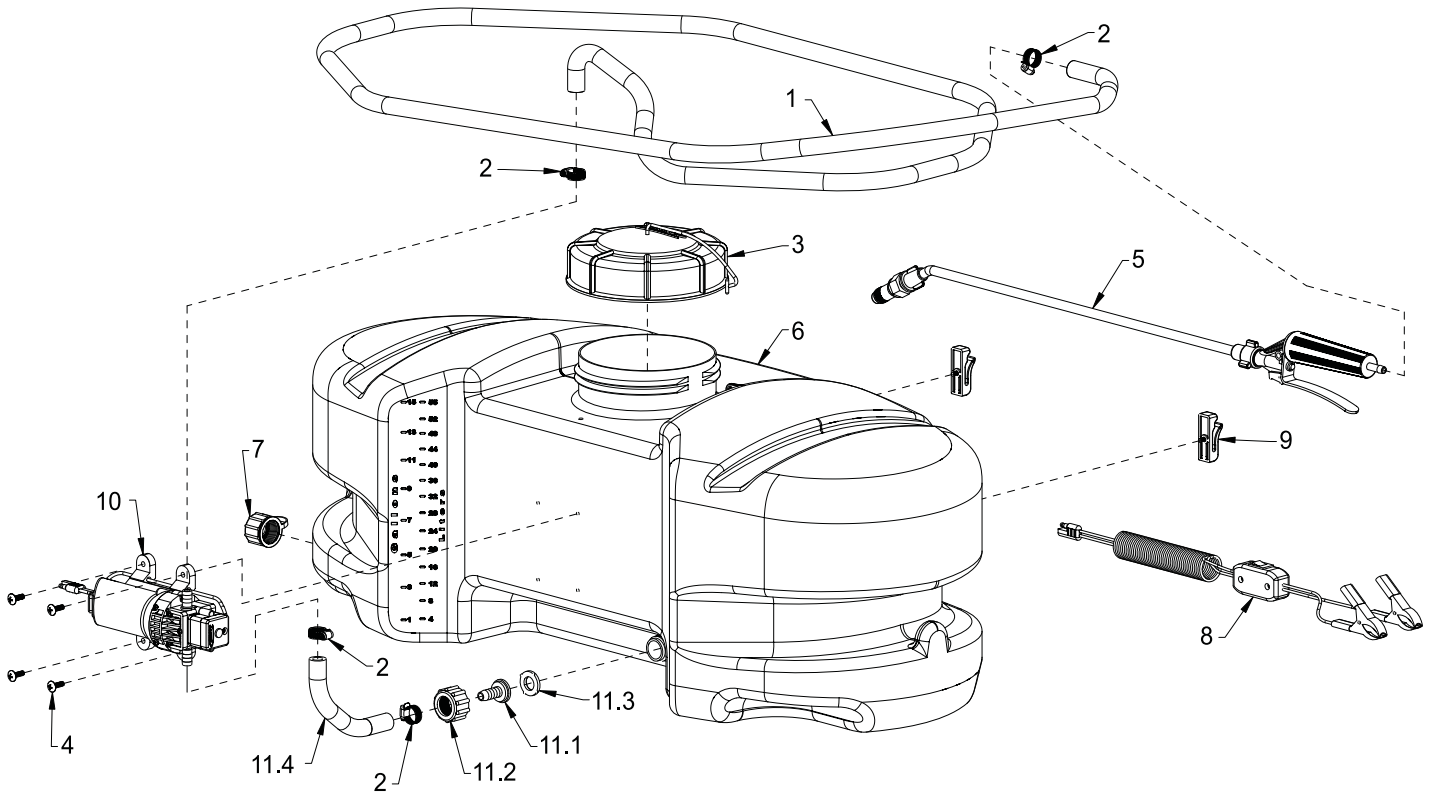

| Item No. | Part Number | Qty | Description |
|----------|-------------|-----|---|
| 1 | 5020215 | 1 | Hose, 3/8"-1 Brd. x 15 Ft. |
| 2 | 5051114 | 4 | Hose Clamp, 3/8" |
| 3 | 5058183 | 1 | FIMCO 5" Threaded Tank Lid |
| 4 | 5117167 | 4 | #10-24 x 5/8" Phillips Truss Head Machine Screw |
| 5 | 5163100 | 1 | Low-Flow Handgun w/X-26 Tip |
| 6 | 5169242 | 1 | 15 Gallon (New Style) Tank |
| 7 | 5274373 | 1 | Drain Plug Cap, Tether, and Washer Assembly |
| 8 | 5274443 | 1 | Lead Wire Assembly (w/Switch), 96" |
| 9 | 5274880 | 1 | Pkg. (2) Handgun Clips & (2) Screws |
| 10 | 5275496 | 1 | New Generation 1.0 g.p.m. Pump |
| 11 | 5275511 | 1 | Inlet Sub-Assembly (EC Units) |
| 11.1 | 5149034 | 1 | Poly Swivel, 3/8" Hose Barb |
| 11.2 | 5006209 | 1 | Poly Knurled Swivel Nut, 3/4" FGHT |
| 11.3 | 5116242 | 1 | Strainer, 1" Filter Washer |
| 11.4 | 5020095 | 1 | Hose, 3/8"-1 Brd. x 6 1/2" |