

2170 COMMERCIAL BROADCAST SPREADER

ASSEMBLY and OPERATING INSTRUCTIONS Rev.1-09

EarthWay
EV-N-SPRED
GT

PLEASE CALL IF YOU ARE MISSING ANY PARTS, HAVE ANY DIFFICULTY IN ASSEMBLY, OR HAVE ANY QUESTIONS REGARDING THE SAFE OPERATION OF THIS SPREADER. THIS MODEL INCLUDES **LIFETIME TECHNICAL SUPPORT** SUPPORT HOT LINE: 574-848-7491 or 800-294-0671, EMAIL: TECHSUPPORT@EARTHWAY.COM

HELPFUL HINTS: READ THE DIRECTIONS BEFORE ASSEMBLY

- ☑ If your spreader does not spread evenly, be sure the FRONT on the gear box points to the front of the spreader. The impeller must turn clockwise. Reversing the gearbox will cause the impeller to turn counter clockwise. Clean the impeller plate after each use. Fertilizer stuck on the impeller blades will cause uneven spreading.
- ☑ Your spreader is designed to be pushed at three miles per hour, which is a brisk walking speed. Slower or faster speeds will change the spread patterns. Wet fertilizer will also change the spread pattern and flow rate. Clean and dry your spreader thoroughly after each use. A coating of light spray oil will help prevent corrosion. Wash between the shut off plate and bottom of the hopper.
- ☑ Gears are permanently lubricated at the factory. Do not open the gearbox or dirt may enter.

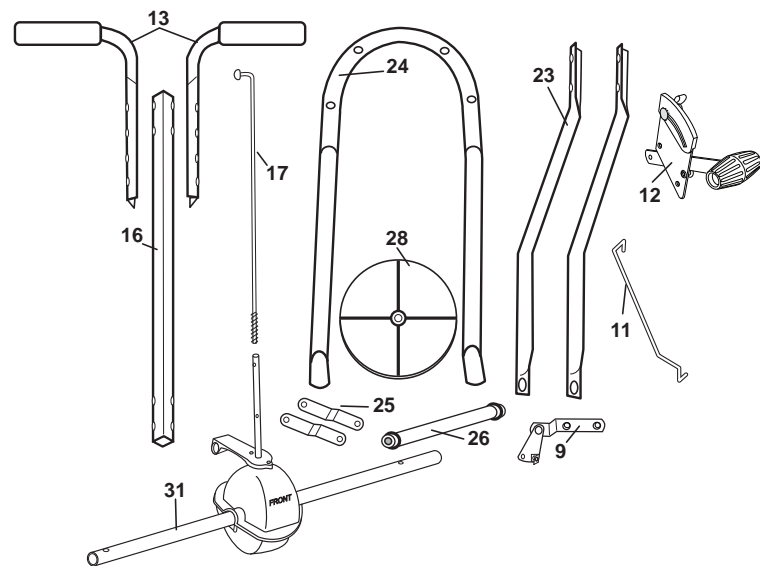
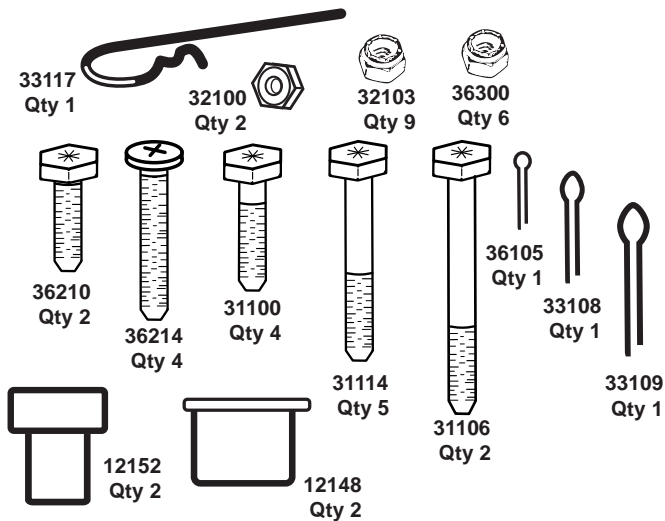

1. Remove and identify all loose parts from carton.

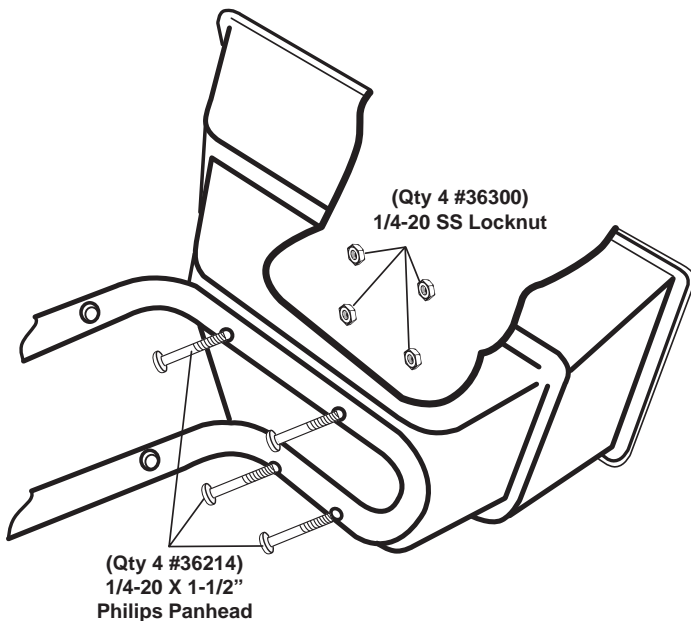

2. Position hopper on side. Install frame using (4) 1/4-20 x 1-1/2" Pan Head Philips bolts and (4) 1/4-20 nylon insert locknuts. First put bolts through holes in frame then through holes in bottom of hopper. Secure with locknuts. **TIGHTEN THESE LOCKNUTS NOW - DO NOT TIGHTEN WITH POWER TOOLS.**

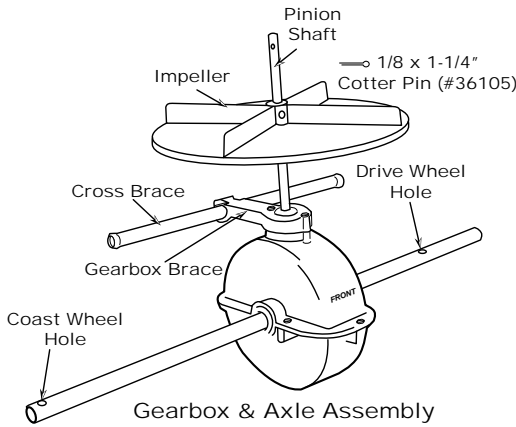

3. Install impeller onto pinion shaft. Insert 1/8"x 1/4" cotter pin through impeller then through pinion shaft. Use hole closest to the gear box. Spread cotter pin to prevent from falling out. Next insert Cross Brace thru the Gearbox Brace as shown above.

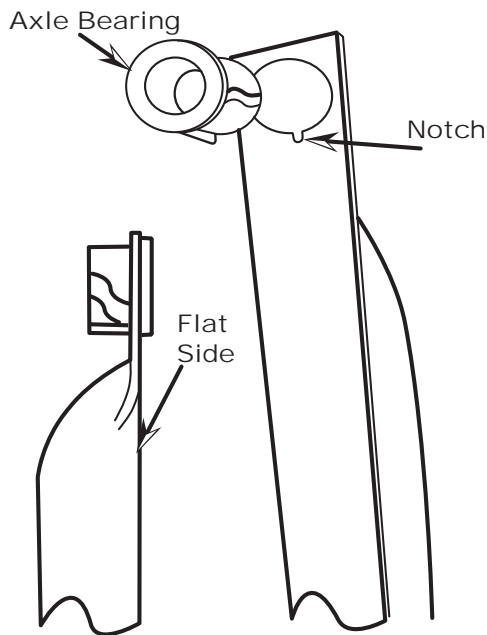

5. Install axle bearings to both lower handles. **NOTE:** Notch on bearings and lower handles. Bearings must go through flat side of lower handle.

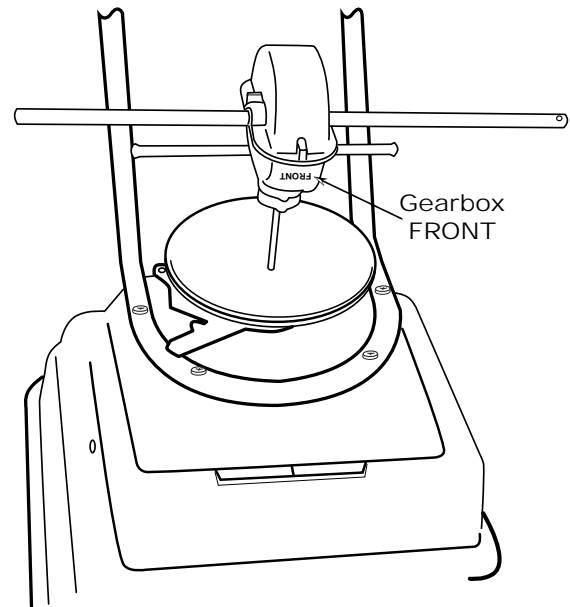

4. Install gear box by inserting the pinion shaft into hole in center of hoppers bottom. The word "FRONT" on the gearbox must point to Front of the hopper. Follow label instructions on hopper.

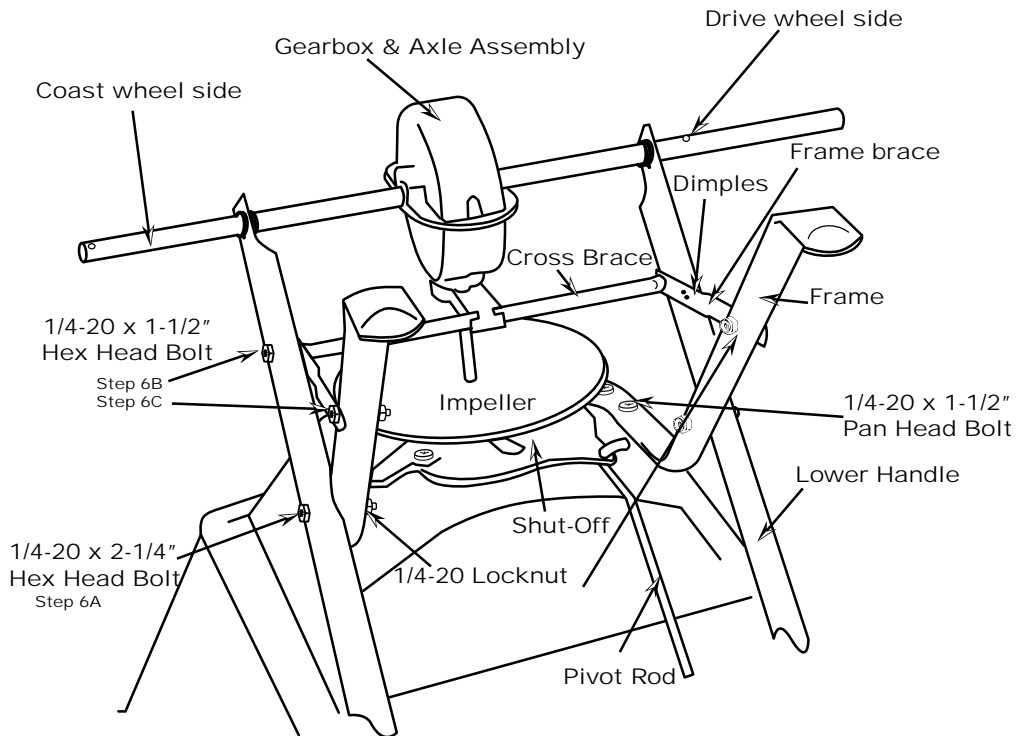

6. **A** - Install lower handles onto axle to both sides as shown. Insert 2/4" bolt through second hole in lower handle and through first hole in frame install locknut. **DO NOT TIGHTEN.**
B - Now insert 1/2" bolt through first hole in lower handle. Then through frame brace. **NOTE:** Dimples on frame brace must be facing toward gear box as shown. Next into threaded connector in cross brace. **DO NOT TIGHTEN.**
C - Next insert 1/2" bolt through other end of frame brace and through second hole in frame install locknut.

NOW GO BACK AND TIGHTEN ALL NUTS AND BOLTS STARTING WITH FIRST STEP. DO NOT OVER TIGHTEN.

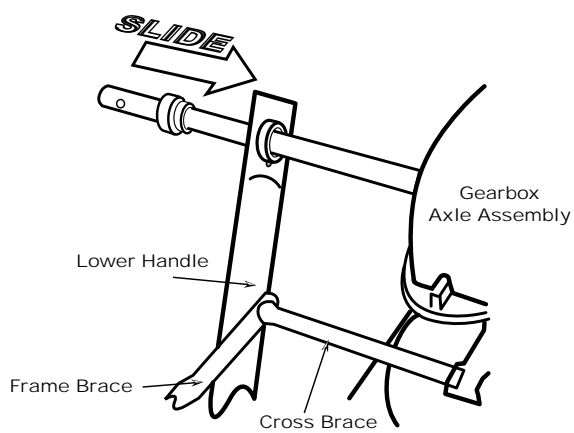

7. Slide axle bushing over axle and into axle bearing to both sides as shown.

8. Install drive wheel to axle using pin hole nearest to lower handles as shown. Insert 2" cotter pin through wheel and through axle. Bend with pliers to prevent pin from falling out.

9. Install coast wheel to axle using outside pin hole. As shown, insert 1" cotter pin through axle (not thru the wheel). Bend with pliers to prevent pin from falling out.

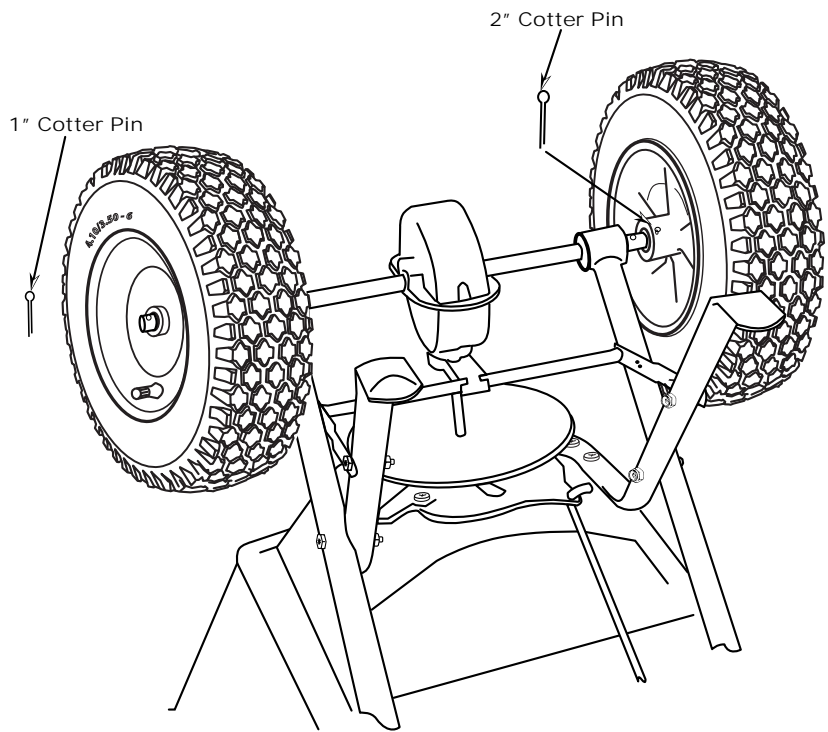

TURN SPREADER UPRIGHT ON TO WHEELS.

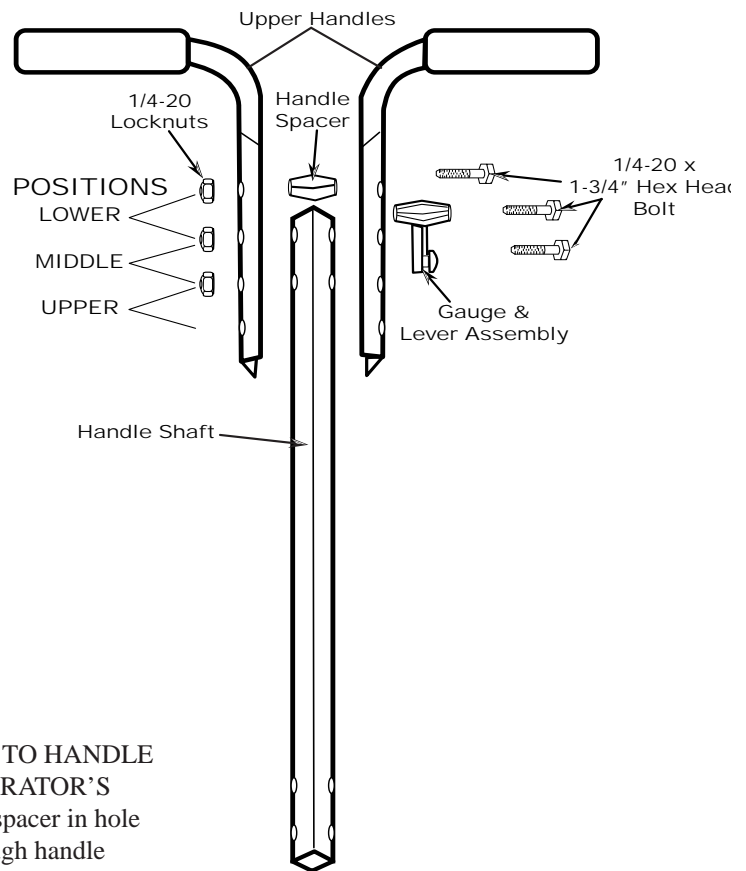
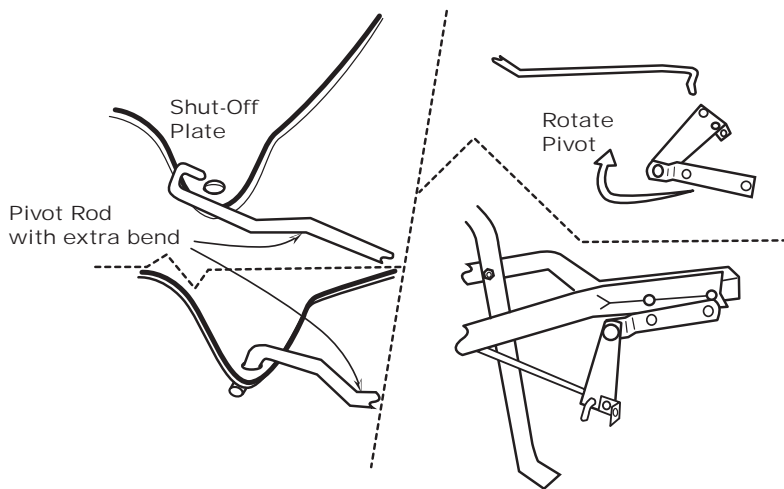

10. **NOTE:** BEFORE INSTALLING GAUGE AND UPPER HANDLES TO HANDLE SHAFT, UPPER HANDLES FEATURE THREE POSITIONS FOR OPERATOR'S COMFORT. If operator chooses middle or upper positions, use handle spacer in hole nearest to handle grips. Insert 1 3/4" bolt through upper handle, then through handle spacer through other upper handle. DO NOT TIGHTEN LOCKNUT YET. TIGHTEN THIS NUT LAST. Install gauge & lever using (2) 1 3/4" bolts. Be sure gauge is on left hand side. Tighten locknuts to gauge first. TIGHTEN NOW.

11. Insert pivot rod into shut off plate as shown. Turn to lock in place.

12. Insert other end of pivot rod into pivot and bracket assembly as shown. Turn to lock in place.

13. Install handle shaft to lower handles and pivot & bracket assembly as shown. Using 1/4 -20 x 1-3/4" bolts and locknuts. **TIGHTEN BOLTS AND NUTS NOW.**

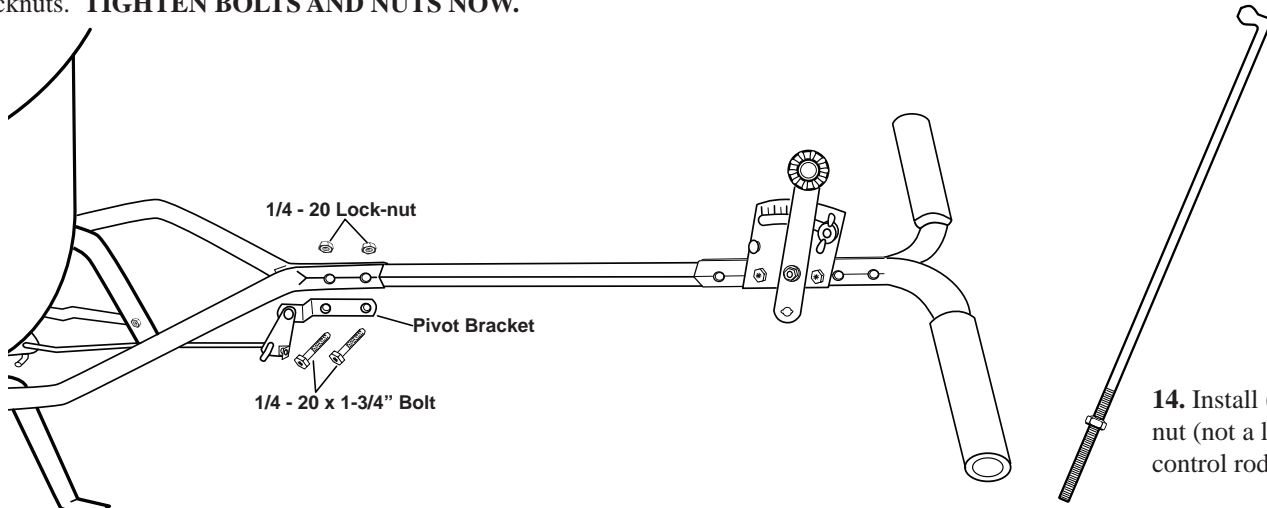

14. Install (1) 1/4-20 Hex nut (not a locknut) on to control rod as shown.

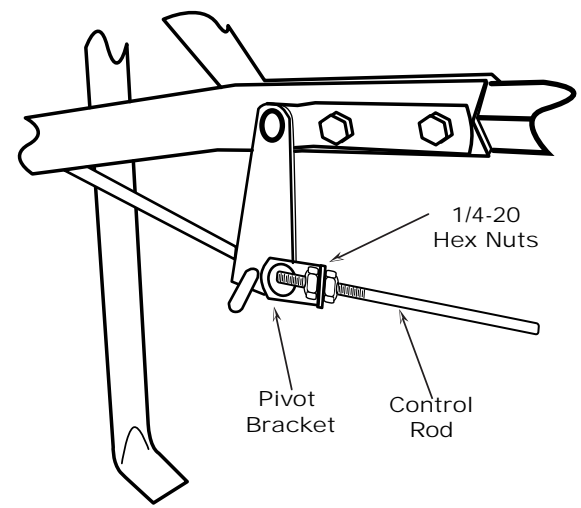
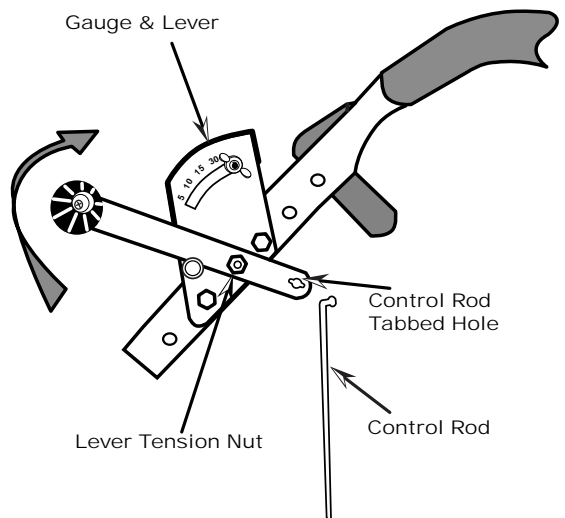

15. Install flattened end of control rod in to lever on gauge as shown. Turn to lock in place. Next push lever forward to setting "0". Align control rod with hole in pivot bracket, pull lever backward to insert control rod through hole in pivot bracket. Now install 1/4-20 Hex nut on to control rod.

16. Pull lever back to setting "30" as shown. Next push pivot & bracket forward so that the shut off plate in the hopper is in the full open position. **REMEMBER SETTING "30" ON THE FLOW CONTROL LEVER MUST PLACE THE SHUT-OFF PLATE IN THE FULL OPEN POSITION TO BE PROPERLY CALIBRATED.** Now tighten the nuts against the pivot bracket to prevent change in calibration.

17. Tension on the flow control lever may be adjusted by tightening or loosening the tension nut as shown.

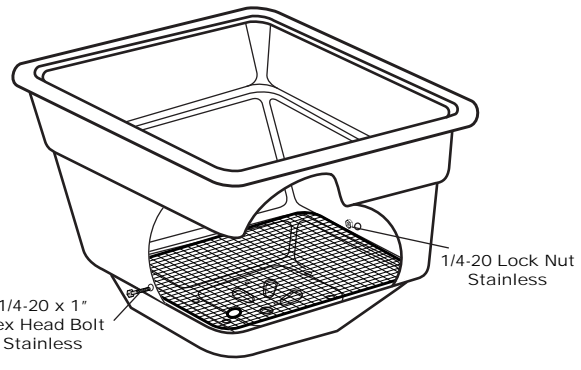
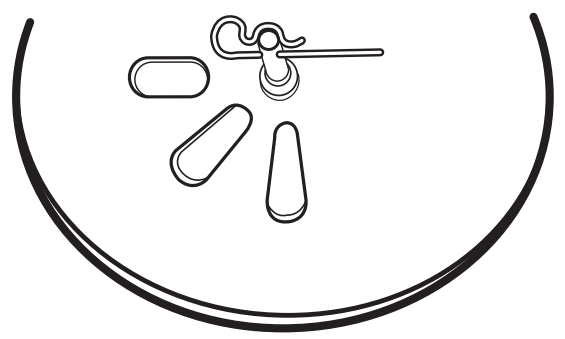

18. Insert agitator to pinion shaft on inside of hopper. **Note:** the position of flat side of the agitator. This pin should be installed as shown.

19. Install debris screen into hopper, then insert 1/4-20 x 1" Stainless Steel Hex Bolt thru the hole in the side wall of the hopper. Secure with Stainless Steel lock nut - **TIGHTEN WITH HAND TOOLS ONLY**

5-YEAR LIMITED WARRANTY

EarthWay Products, Inc. warrants this product to be free of defects in original workmanship and materials for a period of 5-Years to the end user with the original purchase receipt. If a manufacturing non-conformance is found, **EarthWay** Products, Inc. at its discretion will repair or replace the part(s) or product at no charge provided the failure is not the result of incorrect installation, mishandling, misuse, tampering, or normal wear and tear as determined by **EarthWay**. **EarthWay** at its discretion may require that the part(s) or product be returned along with the original purchase receipt at owners' expense for examination and compliance with the terms of this warranty. (Do not return any product without first receiving authorization from **EarthWay** Products, Inc.). To seek remedy under this warranty, contact **EarthWay** Products, Inc. at 574-848-7491, techsupport@earthway.com or write to (**EarthWay** Products, Inc. P.O. Box 547 Bristol, Indiana 46507) and describe the nature of the manufacturing defect. **SPECIFIC LIMITATIONS:** This warranty covers only the part(s) or product; any labor charges associated with repair or replacement of non-conformances are specifically excluded. Due to the corrosive nature of most fertilizers and ice melt products, **EarthWay** Products, Inc. makes no warranty against and specifically excludes part(s) or product degradation or failure due to corrosion or its effects. Clean and dry your spreader thoroughly after each use, as a preventative measure, coat all metal parts with a light oil or silicon spray.

HOW TO ORDER SPARE PARTS

All spare parts listed herein may be ordered direct from the manufacturer. Be sure to give the following information when ordering.

- Model Number
- Part Number
- Part Description

You can contact us by calling (574) 848-7491 or 800-294-0671 to place an order with a credit card.

Questions? parts@earthway.com

OPERATING INSTRUCTIONS

Before filling hopper, become familiar with the operation of this spreader.

1. Obtain proper setting for material to be used from the RATE SETTING CHART included with this spreader.
2. Move stop bolt on rate gauge assembly to the proper setting.
3. While pushing spreader forward, pull control lever back to stop bolt.
4. To stop, push lever forward to close flow holes before you stop moving.
5. When finished, empty any remaining material from hopper.
6. Thoroughly wash spreader and allow to dry before storing. Light oiling can prevent corrosion.

The settings furnished on the Rate Setting Matrix are intended as a guide only. Variations in physical characteristics of material applied, walking speed, and roughness of ground surface may require slightly different spreader settings. Due to the above conditions, the manufacturer makes no warranty as to the uniformity of coverage actually obtained from the settings listed.

Full Rate Path

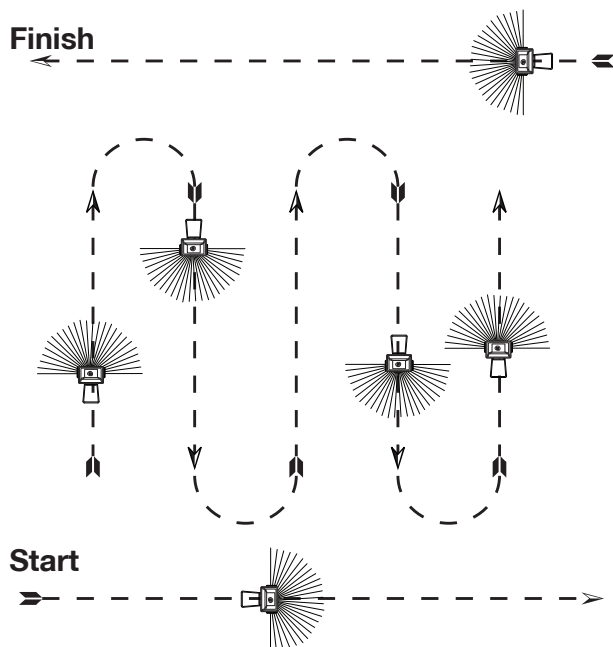

Half Rate Path

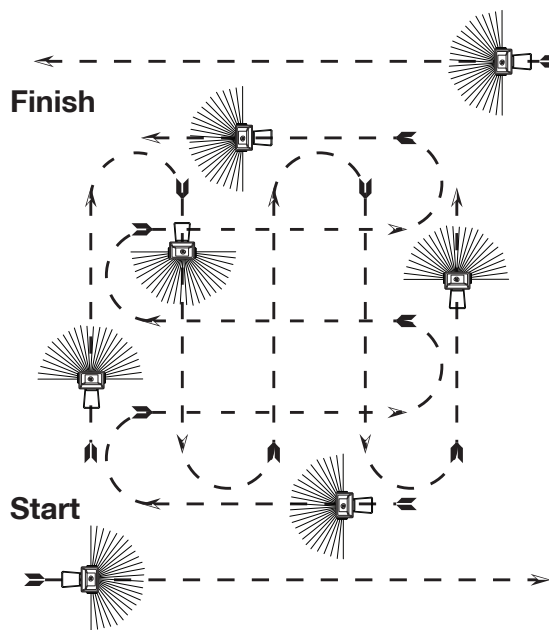

2170 Broadcast Spreader

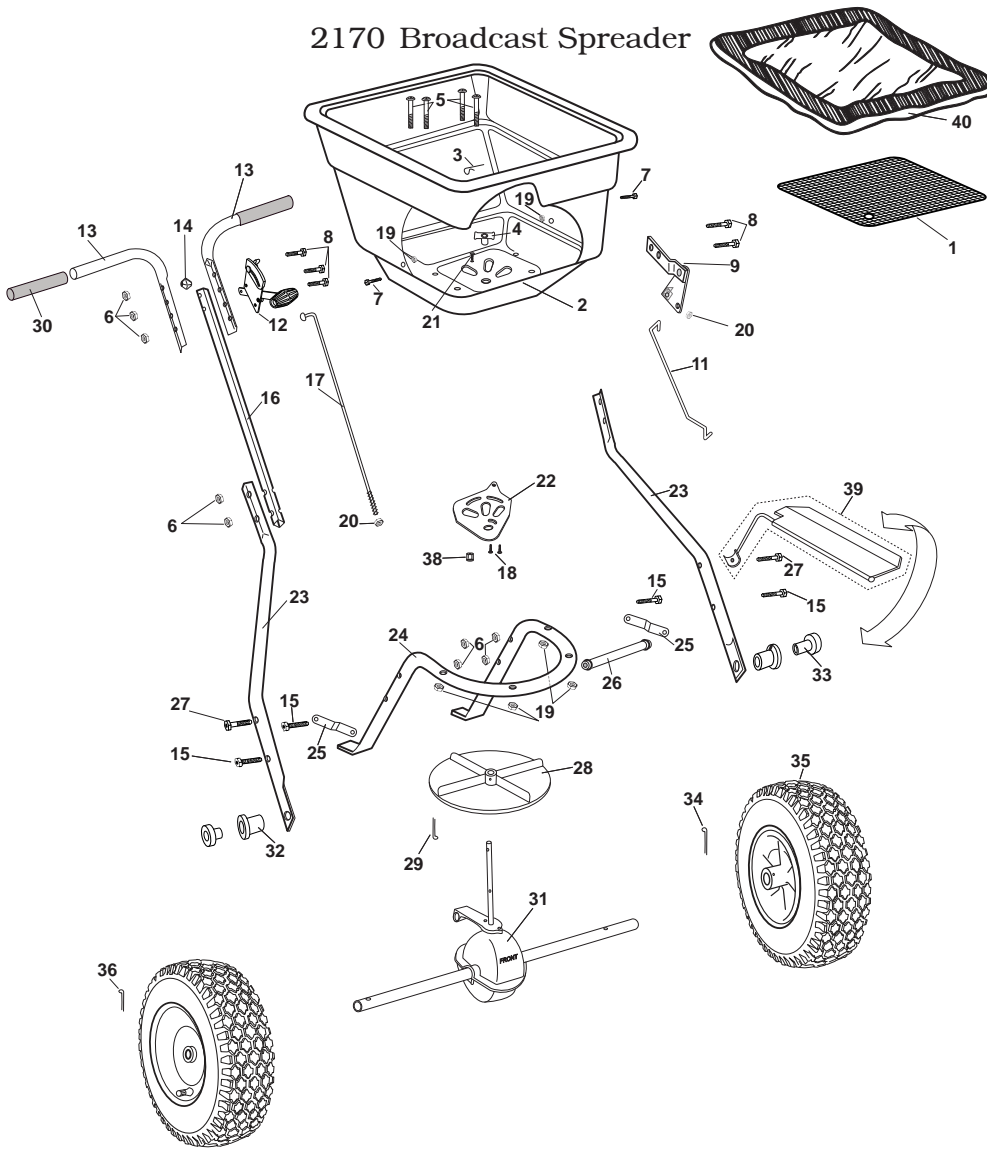

EarthWay Products, Inc.
 P.O. Box 547
 Bristol, IN 46507
 Phone: 800-294-0671
 www.earthway.com

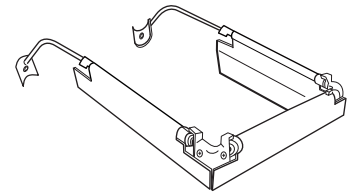

60166R Side Deflector Kit

2170 Broadcast Spreader ~ Parts List

Key #	Part #	Description	Key #	Part #	Description
1	40003	Screen	22	12317	Shut-Off
2	60335	Hopper Assembly, Includes Key #4 & 22	23	25222	Lower Handle
3	33117	Agitator	24	25106	Frame
4	12209	Hopper Bushing	25	44249	Frame Brace
5	36214	1/4-20 X 1-1/2" PHPMS SS	26	25228	Cross Brace
6	32103	1/4-20 Nylon Locknut	27	31106	1/4-20 X 2-1/4" Bolt
7	36210	1/4-20X 1" SS Bolt	28	12109	Impeller
8	31114	1/4-20 X 1-3/4" Bolt	29	36105	1/8" X 1-1/4" Cotter Pin
9	60300	Pivot & Bracket Assembly	30	12274	Handle Grip
11	44251	Pivot Rod	31	60334	Gear Box & Axle Assembly
12	60298	Gauge & Lever Assembly	32	12148	Axle Bearing
13	60175	Upper Handle, Includes Grip	33	12152	Axle Bushing
14	12344	Handle Spacer	34	33109	3/16" X 2" Cotter Pin
15	31100	1/4-20 X 1-1/2" Bolt	35	70138	Drive Wheel/Coast Wheel
16	25223	Handle Shaft	36	33108	3/16" X 1" Cotter Pin
17	42256	Control Rod	38	11927	Shut-off Support - large
18	31138	#8 X 3/8" PMT Screw	39	60060R	Opt. Heavy Duty Rain Cover & Side Deflector Kit
19	36300	1/4-20 SS Nylon Locknut	40	77002	Optional Heavy Duty Rain Cover
20	32100	1/4-20 Hex nut		60166R	Optional 3-Side Deflector Kit
21	36208	#6 X 3/8" PHP SS			