

**SPECIAL UNITS ARE NON-RETURNABLE
 *AVAILABLE AT ADDITIONAL COSTS

ALL TERRAIN PALLET TRUCK, ALL-T-2

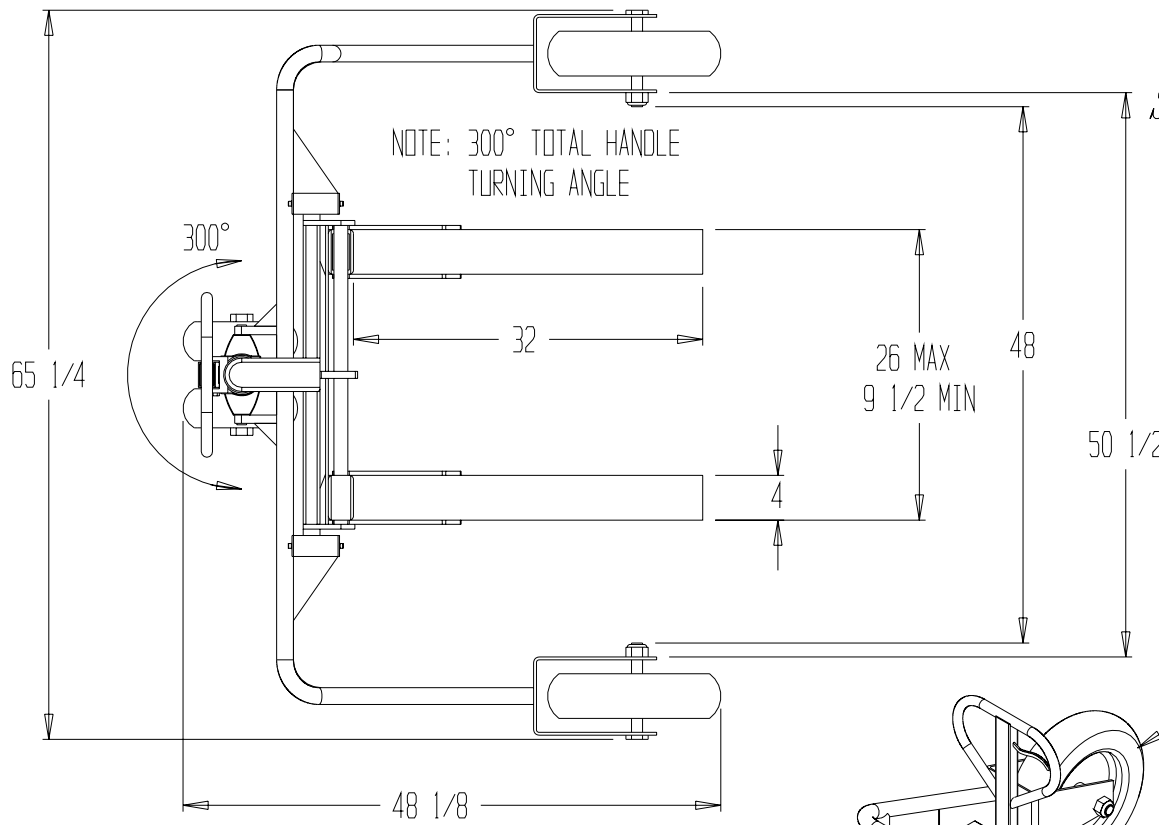

SPECIAL FEATURES
 NONE

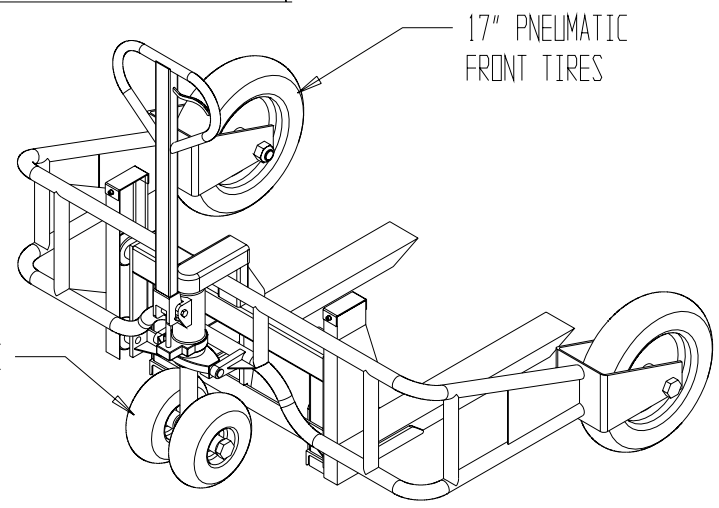
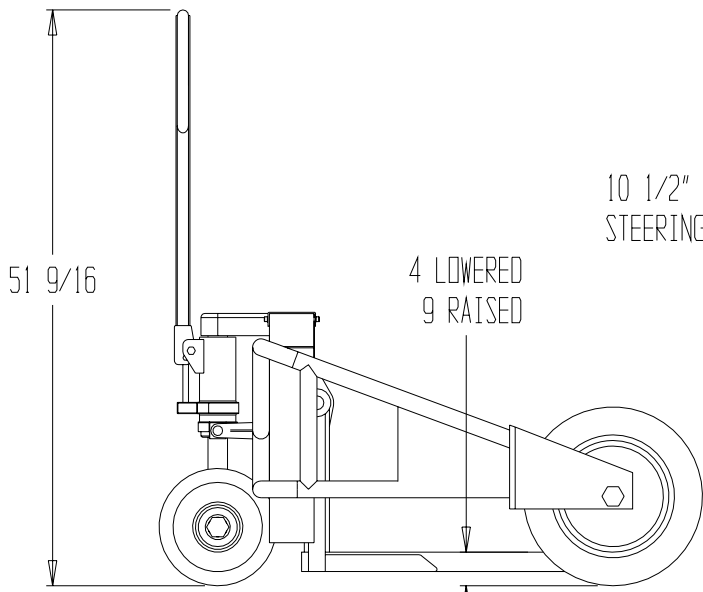

3-D REFERENCE
 SCALE 1:20

PRODUCTION WILL START UPON
 RECEIPT OF SIGNED APPROVAL
 DRAWING

STANDARD FEATURES

- MODEL NUMBER: ALL-T-2
- CAPACITY: 2,000 LB. AT 12" HORIZONTAL LOAD CENTER
 1,500 LB. AT 15" HORIZONTAL LOAD CENTER
- OVERALL WIDTH: 64 1/2"
- OVERALL LENGTH: 47 7/8"
- OVERALL HEIGHT: 51 9/16"
- OVERALL FORK WIDTH: 9 1/2" TO 26"
- FORK LENGTH: 32"
- FORK LOWERED HEIGHT: 4"
- FORK RAISED HEIGHT: 9"
- INDIVIDUAL FORK WIDTH: 4"
- STRADDLE I.D.: 50 1/2"

APPROVAL

I, the undersigned, hereby approve this print
 As drawn As marked
 This includes my approval of design & dimensions.
 Signed: _____
 Date: _____

DISTRIBUTOR'S NAME: VESTIL MANUFACTURING		P.O.#: _
DRAWN BY: S ROSE		W.O.#: _
DATE: 6-1-04		SALES: _
REFERENCE: -		DRWG./FILE NAME: ALL-T-0-2-APP
scale: 1:18		